



Key Features



- 0.35 ~ 2.0 GHz
- 0.75 dB noise figure
- 30.0 dBm Output IP₃
- 25.0 dB Gain
- +/-0.30 dB Gain Flatness
- 18.0 dBm P_{1dB}
- 1.45:1 VSWR
- Single Power Supply
- >34 years MTBF
- Unconditional Stable
- Field Replace SMA

Product Description

WBA0320A integrates WanTcom proprietary low noise amplifier technology, high frequency micro electronic assembly techniques, and high reliability design to realize optimum low noise figure, wideband, high linearity, and unconditional stable performances together. With single +12.0V DC operation, the amplifier has optimal input and output matching in the specified frequency range at 50-Ohm impedance system. The amplifier has standard field replaceable SMA connectors with gold plated housing.

The amplifier is designed to meet the rugged standard of MIL-STD-202.

Applications

- Mobile Infrastructures
- GPS
- CATV/DBS
- Defense
- Security System
- Measurement
- Fixed Wireless



Specifications

Summary of the electrical specifications WBA0320A at room temperature

Index	Testing Item	Symbol	Test Constraints	Min	Nom	Max	Unit
1	Gain	S ₂₁	0.35 – 2.0 GHz	24	25	27	dB
2	Gain Variation	ΔG	0.35 – 2.0 GHz		+/- 0.3	+/-0.5	dB
3	Input VSWR	SWR ₁	0.35 – 2.0 GHz		1.45:1	1.5:1	Ratio
4	Output VSWR	SWR ₂	0.35 – 2.0 GHz		1.45:1	1.5:1	Ratio
5	Reverse Isolation	S ₁₂	0.35 – 2.0 GHz		40		dB
6	Noise figure	NF	0.35 – 0.50 GHz		0.85	1.0	dB
			0.50 – 2.0 GHz		0.75	0.85	
7	Output Power 1dB compression Point	P _{1dB}	0.35 – 2.0 GHz		18		dBm
8	Output-Third-Order Interception point	IP ₃	Two-Tone, P _{out} +0 dBm each, 1 MHz separation	27	30		dBm
9	Current Consumption	I _{dd}	V _{dd} = +12V or +5 V		105		mA
10	Power Supply Voltage	V _{dd}	WBA0320B	+4.7	+5	+5.3	V
			WBA0320A	+11	+12	+12.3	
11	Thermal Resistance	R _{th,c}	Junction to case			80	°C/W
12	Operating Temperature	T _o		-40		+85	°C
13	Maximum Average RF Input Power	P _{IN, MAX}	DC – 12 GHz			10	dBm

Absolute Maximum Ratings

Parameters	Units	Ratings
DC Power Supply Voltage	V	12.5 (6 V for WBA0320B)
Drain Current	mA	120
RF Input Power	dBm	10
Channel Temperature	°C	150
Storage Temperature	°C	-55 ~ 125
Operating Temperature	°C	-40 ~ 85
Thermal Resistance	°C/W	80

Operation of this device above any one of these parameters may cause permanent damage.

Ordering Information

Model Number	Feature
WBA0320A	V _{dd} = +12.0V
WBA0320B	V _{dd} = +5.0V

Functional Block Diagram

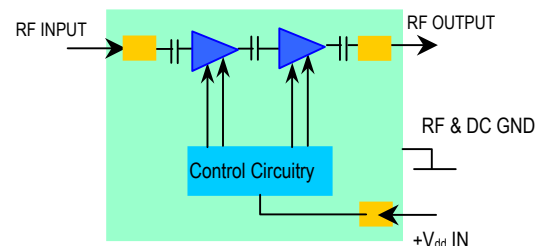

Specifications and information are subject to change without notice.



Typical Data

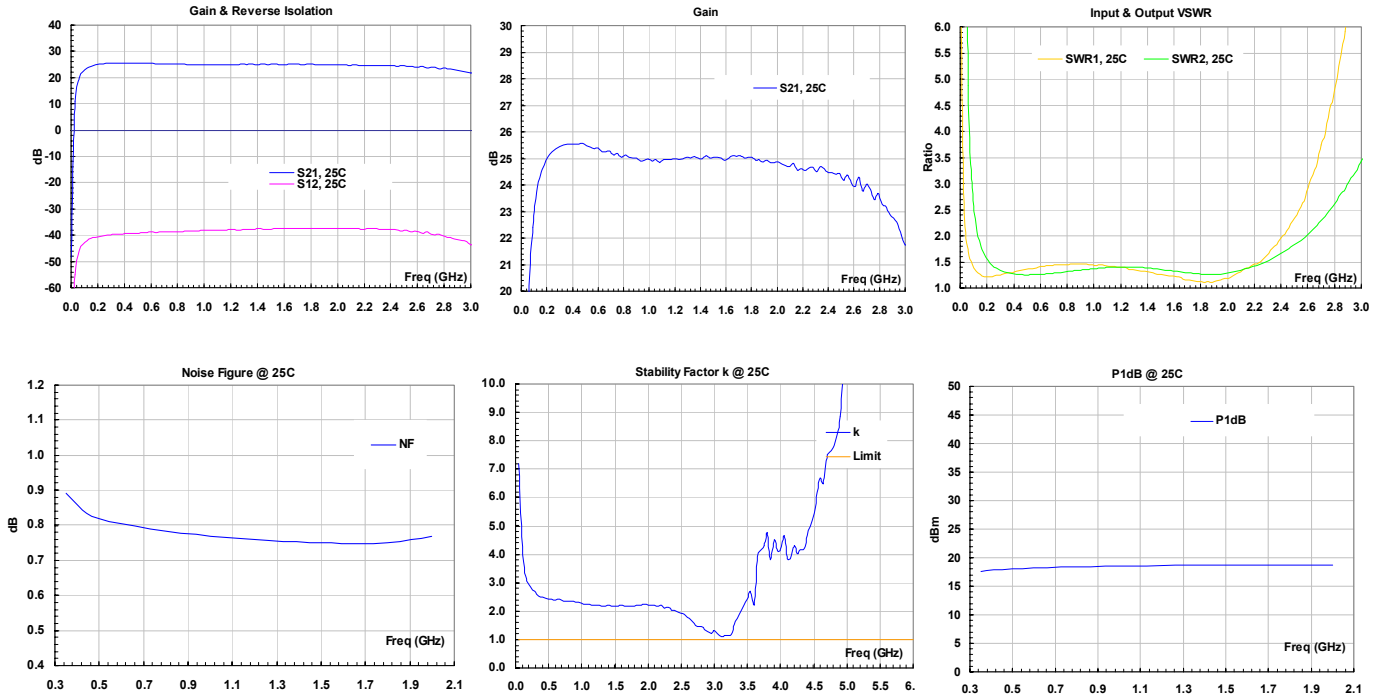

Outline

UNITS: INCH [mm]
 BODY: Brass
 Finish: Gold Plating
 RF Connector: SMA F Gold
 V_{dd} PWR: Feed through

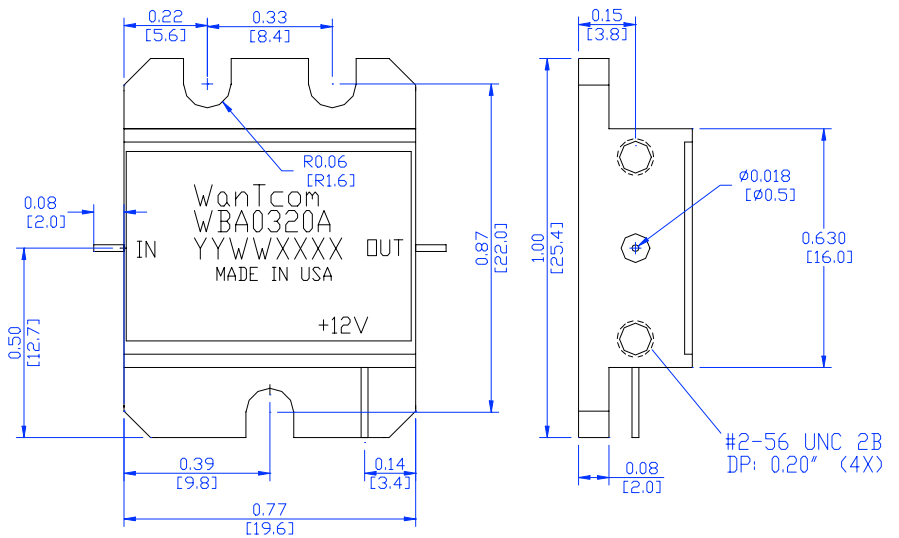

!!Warning: Only use 3/16" long #2-56 screws to mount the SMA connectors. Longer screw may damage the internal components.

Specifications and information are subject to change without notice.



Application Notes:

A. SMA Torque Wrench Selection

Always use a torque wrench with 5 ~ 6 inch-lb coupling torque setting for mating the SMA cables to the amplifier. Never use torque more than 8 inch-lb wrench for tightening the mating cable to the connector. Otherwise, the permanent damage will occur to the SMA connectors of the amplifier. 8710-1582 (5 inch-lb) is one of the ideal torque wrench choice from Agilent Technology.

B. DC Power Line Connection

Strip the insulation layer at the end of DC power supply wire. The stripped distance should be in the range of 0.100" to 0.200". The 24 ~ 26 American Wire Gauge wire is suitable. Wound the stripped terminal wire about 1 to 2 turns on the DC feed thru center pin. Solder the wounded wire and the center pin together. Clean the soldering area by Q-tip with alcohol to remove the flux and residue.

Repeat the process to solder the DC return wire on the ground turret.

C. Mounting the Amplifier

Use three pieces of #2-56 with longer than 1/4" screws for mounting the amplifier on a metal-based chase. Flat and spring washers are needed to prevent the screw loosening during the shock and vibration. Always use the appropriate torque setting of the power screwdriver to mount them.
