



# WBPA0527A

## 0.4 - 2.7 GHz 2-Watt LOW NOISE POWER AMPLIFIER

REV B  
November 2017

### Key Features



- 50 Ohm Impedance
- 0.4 – 2.7 GHz
- +/- 0.7 dB Gain Flatness
- 2.20 dB Noise Figure
- 45.0 dBm Output IP<sub>3</sub>
- 36.0 dB Gain
- 33.0 dBm P<sub>1dB</sub>
- 1.5:1 VSWR
- Single Power Supply
- >34 Years MTBF
- Unconditional Stable
- RoHS Compliant

### Product Description



WBPA0527A is integrated with WanTcom proprietary low noise amplifier technology, high frequency micro electronic assembly techniques, and high reliability design to realize optimum low noise figure, wideband, high linearity, and unconditional stable performances together. With single DC operation, the amplifier has optimal input and output matching in the specified frequency range at 50-Ohm impedance system. The amplifier has standard SMA connectorized WP-9 Gold plated housing.

The amplifier is designed to meet the rugged standard of MIL-STD-202g.

### Applications

- Mobile Infrastructures
- WiMax
- GPS
- CATV/DBS
- Defense
- Security System
- Measurement
- Fixed Wireless



### Specifications

**Additional heat sink required!**

Summary of the electrical specifications WBPA0527A at room temperature

| Index | Testing Item                                    | Symbol               | Test Constraints  | Min   | Nom     | Max    | Unit  |
|-------|---|----------------------|---|-------|---------|--------|-------|
| 1     | Gain  | S <sub>21</sub>      | 0.4 – 2.7 GHz   | 34    | 36      | 38     | dB    |
| 2     | Gain Variation                                  | ΔG                   | 0.4 – 2.7 GHz   |       | +/- 0.7 | +/-1.5 | dB    |
| 3     | Input VSWR                                      | SWR <sub>1</sub>     | 0.4 – 2.7 GHz   |       | 1.5:1   | 2:1    | Ratio |
| 4     | Output VSWR                                     | SWR <sub>2</sub>     | 0.4 – 2.7 GHz   |       | 1.5:1   | 2:1    | Ratio |
| 5     | Reverse Isolation                               | S <sub>12</sub>      | 0.4 – 2.7 GHz   | 60    | 70      |        | dB    |
| 6     | Noise Figure                                    | NF                   | 0.4 – 2.7 GHz   |       | 2.2     | 2.8    | dB    |
| 7     | Output 1dB Gain Compression Point               | P <sub>1dB</sub>     | 0.4 – 2.7 GHz   | 31    | 33      |        | dBm   |
| 8     | Output 3 <sup>rd</sup> Order Interception Point | IP <sub>3</sub>      | Two-Tone, P <sub>out</sub> +10 dBm each, 1 MHz separation               | 43    | 45      |        | dBm   |
| 9     | Output 2 <sup>nd</sup> Order Interception Point | IP <sub>2</sub>      | Two-Tone, P <sub>out</sub> +10 dBm each, 1 MHz separation               | 45    | 47      |        | dBm   |
| 10    | DC Current Consumption                          | I <sub>dd</sub>      | V <sub>dd</sub> = +12V  |       | 600     |        | mA    |
| 11    | Power Supply Voltage                            | V <sub>dd</sub>      |   | +11.7 | +12V    | +12.3  | V     |
| 12    | Thermal Resistance, Junction to case            | R <sub>th,c</sub>    | Last stage transistor, V <sub>ds</sub> = 9.5V, I <sub>ds</sub> = 400 mA |       |         | 18     | °C/W  |
| 13    | Operating Temperature                           | T <sub>o</sub>       |   | -40   |         | +85    | °C    |
| 14    | Maximum Input CW RF Power                       | P <sub>IN, MAX</sub> | DC – 6 GHz  |       |         | 10     | dBm   |

### Absolute Maximum Ratings

| Parameters                           | Units | Ratings   |
|--------------------------------------|-------|-----------|
| DC Power Supply Voltage              | V     | -0.5, 13  |
| Drain Current                        | mA    | 700       |
| Total Power Dissipation              | W     | 0.8       |
| Input CW RF Power                    | dBm   | 10        |
| Junction Temperature                 | °C    | 170       |
| Storage Temperature                  | °C    | -55 ~ 125 |
| Operating Temperature                | °C    | -40 ~ 85  |
| Thermal Resistance, Junction to case | °C/W  | 18        |

Operation of this device above any one of these parameters may cause permanent damage.

### Functional Block Diagram

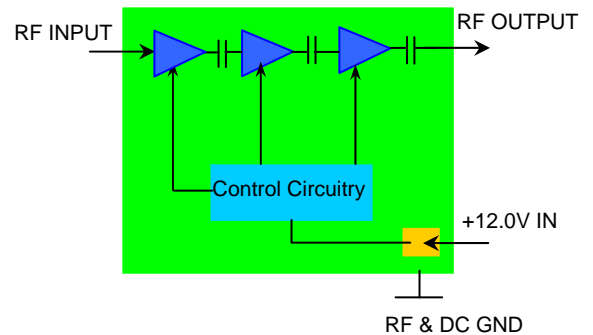

### Ordering Information

|              |           |
|--------------|-----------|
| Model Number | WBPA0527A |
|--------------|-----------|

Specifications and information are subject to change without notice.



**Typical Data**

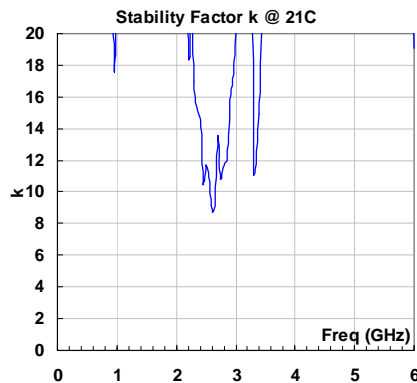
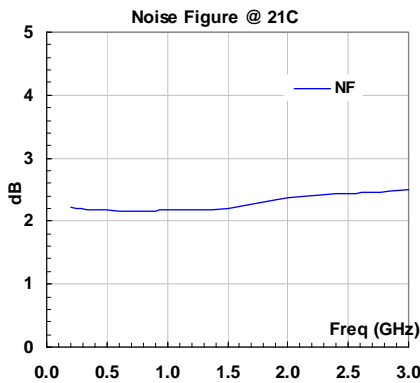
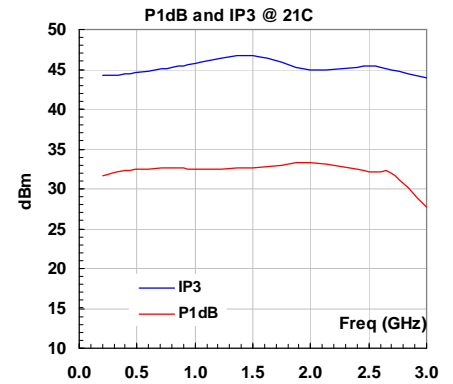
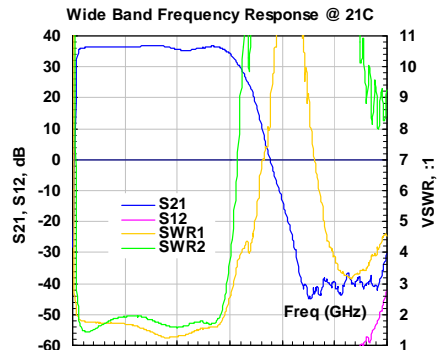
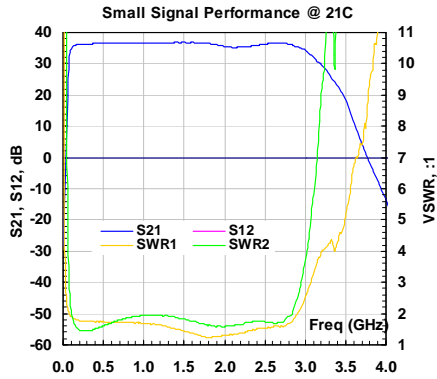

**Outline, WP-9 Housing**

UNITS: INCH [mm]  
 BODY: Brass  
 Finish: Gold Plating  
 RF Connector: SMA F Stainless Steel  
 V<sub>dd</sub> PWR: Feed through

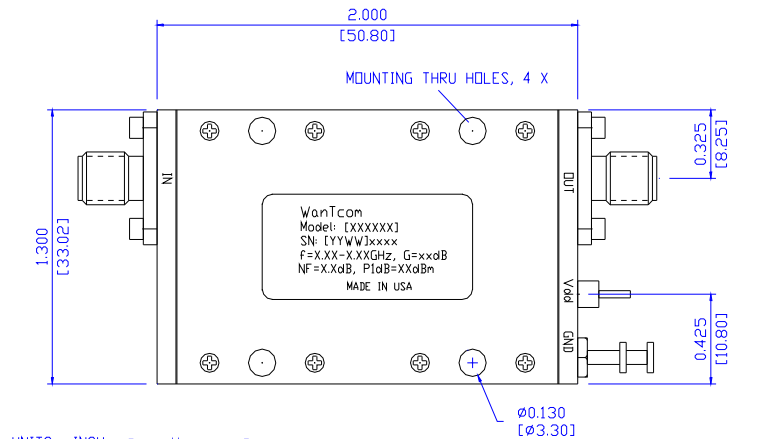

UNITS: INCH [mm] Base Material: Brass. Finish: Gold Plating.

SMA F, STAINLESS STEEL, 2 X

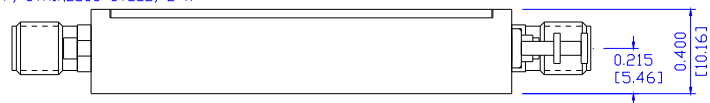

Specifications and information are subject to change without notice.



### Application Notes:

#### A. SMA Torque Wrench Selection

Always use a torque wrench with 5 ~ 6 inch-lb coupling torque setting for mating the SMA cables to the amplifier. Never use torque more than 8 inch-lb wrench for tightening the mating cable to the connector. Otherwise, the permanent damage will occur to the SMA connectors of the amplifier. 8710-1582 (5 inch-lb) is one of the good torque wrench choice from Agilent Technology.

#### B. DC Power Line Connection

Strip the insulation layer at the end of DC power supply wire. The stripped distance should be in the range of 0.100" to 0.200". The 24 ~ 26 American Wire Gauge wire is suitable. Wound the stripped terminal wire about 1 to 2 turns on the DC feed thru center pin. Solder the wounded wire and the center pin together. Clean the soldering area by Q-tip with alcohol to remove the flux and residue.

Repeat the process to solder the DC return wire on the ground turret.

#### C. Mounting the Amplifier

Use four pieces of #4-40 with longer than 9/16" screws for mounting the amplifier on a metal-based chase. Flat and spring washers are needed to prevent the screw loosening during the shock and vibration. Always use the appropriate torque setting of the power screwdriver to mount them. Additional heat sink is required. T-gon thermal film is required between the bottom of the PA and the chase for the effective thermal dissipation. Refer to AN-155 for heat sink design, [http://wantcominc.com/engineering\\_tools.htm](http://wantcominc.com/engineering_tools.htm).

\*\*\*\*\*