



Key Features



- 1.7 ~ 1.9 GHz
- $\infty:1$ Load Handling
- 50.0 dBm output IP₃
- 12.0 dB Gain
- 39 dBm P1dB
- 1.35:1 VSWR
- Single power supply
- >34 years MTBF
- Unconditional stable
- RoHS compliant

Product Description

WBPA1719B integrates WanTcom proprietary low noise amplifier technology, high frequency micro electronic assembly techniques, and high reliability design to realize optimum low noise figure, wideband, high linearity, and unconditional stable performances together. With single +10.0V DC operation, the amplifier has optimal input and output matching in the specified frequency range at 50-Ohm impedance system. The amplifier has standard SMA connectorized WP-6 gold plated housing.

The amplifier is designed to meet the rugged standard of MIL-STD-202.

Applications

- Mobile Infrastructures
- DCS
- PCS
- Defense
- Security System
- Measurement
- Fixed Wireless



Specifications

Summary of the electrical specifications WBPA1719B at room temperature

Index	Testing Item	Symbol	Test Constraints	Min	Nom	Max	Unit
1	Gain	S ₂₁	1.7 – 1.9 GHz		12		dB
2	Gain Variation	ΔG	1.7 – 1.9 GHz		+/- 0.5	+/-0.1	dB
3	Input VSWR	SWR ₁	1.7 – 1.9 GHz		1.35:1	1.8:1	Ratio
4	Output VSWR	SWR ₂	1.7 – 1.9 GHz		1.35:1	1.8:1	Ratio
5	Reverse Isolation	S ₁₂	1.7 – 1.9 GHz		20		dB
6	Maximum Output Load Mis-Match	SWR _{o,MAX}	1.7 – 1.9 GHz			$\infty:1$	Ratio
7	Output Power 1dB compression Point	P _{1dB}	1.7 – 1.9 GHz	37	39		dBm
8	Output-Third-Order Interception point	IP ₃	Two-Tone, P _{out} +0 dBm each, 1 MHz separation	48	50		dBm
9	Current Consumption	I _{dd}	V _{dd} = +10 V		1.60		A
10	Power Supply Voltage	V _{dd}		+9.7	+10	+10.3	V
11	Thermal Resistance	R _{th,c}	Junction to case			4	°C/W
12	Operating Temperature	T _o		-40		+85	°C
13	Maximum Average RF Input Power	P _{IN,MAX}	DC – 6 GHz			28	dBm

Absolute Maximum Ratings

Parameters	Units	Ratings
DC Power Supply Voltage	V	12
Drain Current	A	2.0
Total Power Dissipation	W	18
RF Input Power	dBm	28
Channel Temperature	°C	150
Storage Temperature	°C	-55 ~ 125
Operating Temperature	°C	-40 ~ 85
Thermal Resistance	°C/W	4

Operation of this device above any one of these parameters may cause permanent damage.

Functional Block Diagram

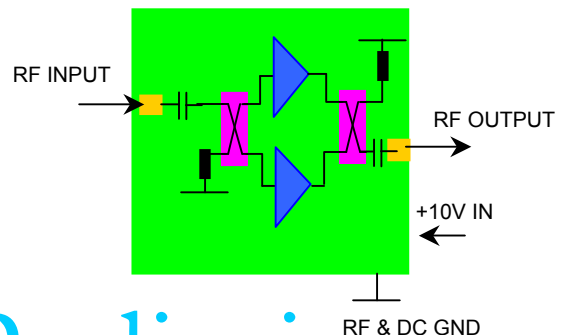

Ordering Information

Model Number	WBPA1719B
---------------------	-----------

Preliminary

Specifications and information are subject to change without notice.



Typical Data

Outline, WP-6 Housing

UNITS: INCH
 [mm]
 BODY: Brass
 Finish: Gold Plating
 RF Connector: SMA F Gold
 V_{dd} PWR: Feed through

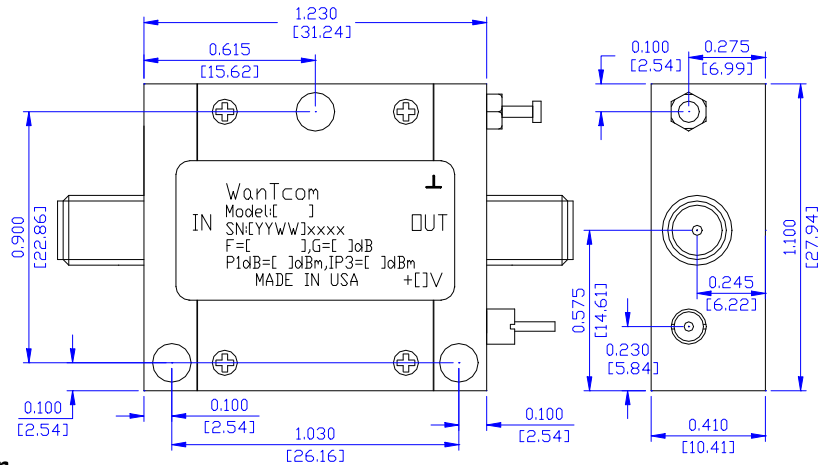

Application Notes:

A. SMA Torque Wrench Selection

Always use a torque wrench with 5 ~ 6 inch-lb coupling torque setting for mating the SMA cables to the amplifier. Never use torque more than 8 inch-lb wrench for tightening the mating cable to the connector. Otherwise, the permanent damage will occur to the SMA connectors of the amplifier. 8710-1582 (5 inch-lb) is one of the good torque wrench choice from Agilent Technology.

B. DC Power Line Connection

Strip the insulation layer at the end of DC power supply wire. The stripped distance should be in the range of 0.100" to 0.200". The 24 ~ 26 American Wire Gauge wire is suitable. Wound the stripped terminal wire about 1 to 2 turns on the DC feed thru center pin. Solder the wounded wire and the center pin together. Clean the soldering area by Q-tip with alcohol to remove the flux and residue.

Repeat the process to solder the DC return wire on the ground turret.

C. Mounting the Amplifier

Use three pieces of #4-40 with longer than 9/16" screws for mounting the amplifier on a metal-based chase. Flat and spring washers are needed to prevent the screw loosening during the shock and vibration. Always use the appropriate torque setting of the power screwdriver to mount them.
