



WBPA1822A

1.8 – 2.2 GHz 4 Watts WIDE BAND POWER AMPLIFIER

REV C
March 2017

Key Features



- 50 Ohm Impedance
- 1.8 ~ 2.2 GHz
- 1.5 dB Noise Figure
- 47.0 dBm Output IP₃
- 24.0 dB Gain
- 36.0 dBm P_{1dB}
- 1.5:1 VSWR
- Single Power Supply
- >34 years MTBF
- Unconditional Stable
- RoHS Compliant

Product Description

WBPA1822A is integrated with WanTcom proprietary low noise amplifier technology, high frequency micro electronic assembly techniques, and high reliability design to realize optimum low noise figure, wideband, high linearity, and unconditional stable performances together. With single +10.0V DC operation, the amplifier has optimal input and output matching in the specified frequency range at 50-Ohm impedance system. The amplifier has standard SMA connectorized WP-6 Gold plated housing.

The amplifier is designed to meet the rugged standard of MIL-STD-202g.

CAUTION:



ELECTROSTATIC DISCHARGE SENSITIVE

Applications

- Mobile Infrastructures
- PCS & 3G
- PA Driver
- Defense
- Security System
- Measurement
- Fixed Wireless



Specifications

Summary of the electrical specifications WBPA1822A at room temperature

Index	Testing Item	Symbol	Test Constraints	Min	Nom	Max	Unit
1	Gain	S ₂₁	1.8 – 2.2 GHz	22	24	26	dB
2	Gain Variation	ΔG	1.8 – 2.2 GHz		+/- 0.2	+/-0.5	dB
3	Input VSWR	SWR ₁	1.8 – 2.2 GHz		1.5:1	2:1	Ratio
4	Output VSWR	SWR ₂	1.8 – 2.2 GHz		1.5:1	2:1	Ratio
5	Reverse Isolation	S ₁₂	1.8 – 2.2 GHz	40	45		dB
6	Noise Figure	NF	1.8 – 2.2 GHz		1.5	2.0	dB
7	Output Gain 1dB Compression Point	P _{1dB}	1.8 – 2.2 GHz	34	36		dBm
8	Output-Third-Order Interception Point	IP ₃	Two-Tone, P _{out} +24 dBm each, 1 MHz separation	43	47		dBm
9	DC Current Consumption	I _{dd}	V _{dd} = +10 V		1.1		A
10	Power Supply Voltage	V _{dd}		+9.5	+10	+10.5	V
11	Thermal Resistance	R _{th,c}	Junction to case			9	°C/W
12	Operating Temperature	T _o		-40		+85	°C
13	Maximum Input CW RF Power	P _{IN,MAX}	DC – 6 GHz			20	dBm

Absolute Maximum Ratings

Parameters	Units	Ratings
DC Power Supply Voltage	V	-0.5, +12
Drain Current	A	1.3
Total Power Dissipation	W	12
Input CW RF Power	dBm	20
Channel Temperature	°C	150
Storage Temperature	°C	-55 ~ 125
Operating Temperature	°C	-40 ~ 85
Thermal Resistance	°C/W	9

Operation of this device above any one of these parameters may cause permanent damage.

Ordering Information

Model	WBPA1822A
-------	-----------

Functional Block Diagram

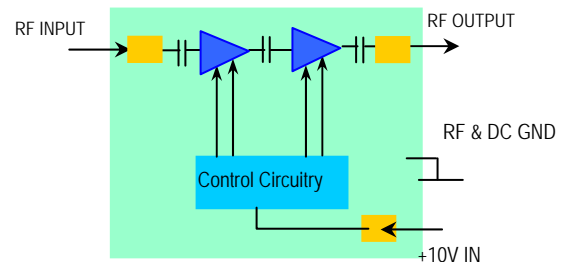

Specifications and information are subject to change without notice.



Typical Data

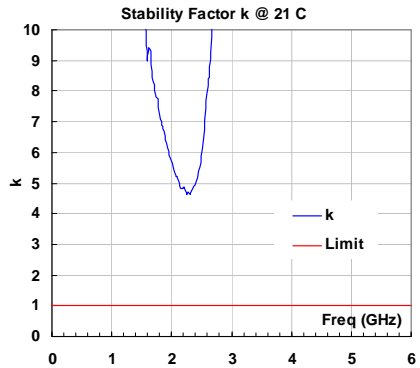
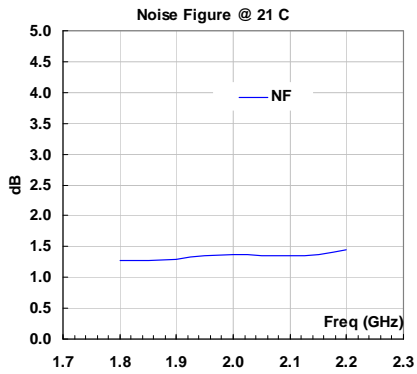
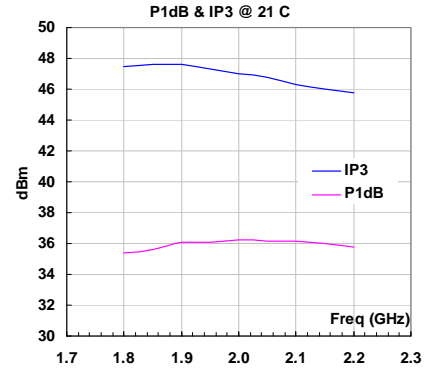
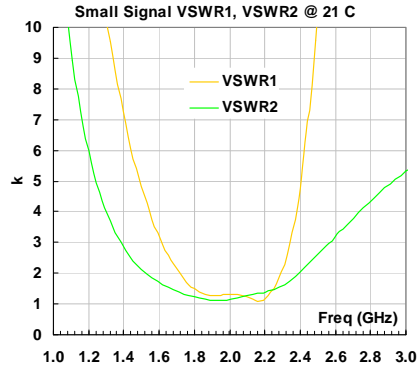
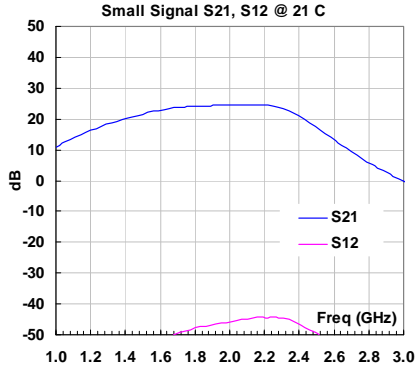



Outline, WP-6 Housing

UNITS: INCH [mm]
 BODY: Brass
 Finish: Gold Plating
 RF Connector: SMA F Gold
 V_{dd} PWR: Feed through

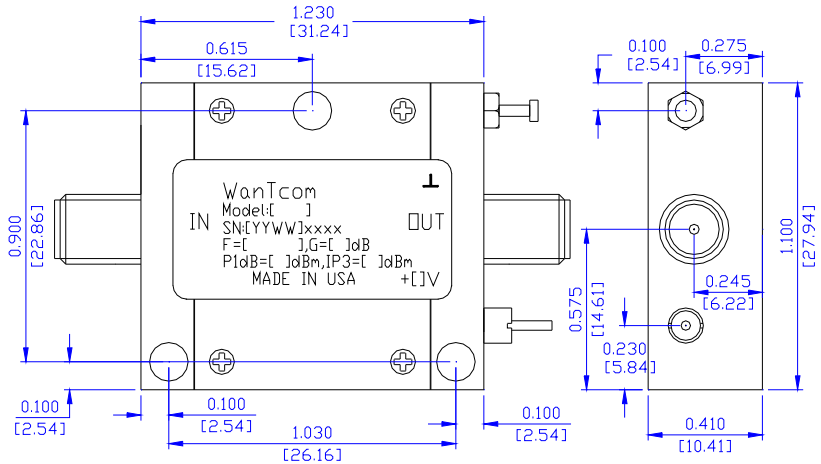

Application Notes:

A. SMA Torque Wrench Selection

Always use a torque wrench with 5 ~ 6 inch-lb coupling torque setting for mating the SMA cables to the amplifier. Never use torque more than 8 inch-lb wrench for tightening the mating cable to the connectors. Otherwise, the permanent damage will occur to the SMA connectors of the amplifier. 8710-1582 (5 inch-lb) is one of the ideal torque wrench choice from Agilent Technology.

B. DC Power Line Connection

Strip the insulation layer at the end of DC power supply wire. The stripped length should be around 0.100" to 0.200". The 24 ~ 26 American Wire Gauge wire is suitable. Wound the stripped wire about 3/4 to 1 turn on the DC feed thru center pin. Solder the wounded wire and the center pin together. Clean the soldering joint by a Q-tip with alcohol to remove the flux and residue.

Do not use large soldering iron tip with more than 750 degree Fahrenheit to solder the wire and feed thru pin. Damage may occur to the feed thru. 0.010" size tip with 750 degree Fahrenheit temperature setting is suitable for the soldering works.

Repeat the process to solder the DC return wire on the ground turret. Higher temperature and larger tip can be used for this ground soldering.

C. Mounting the Amplifier

Use three pieces of #4-40 with longer than 9/16" screws for mounting the amplifier on a metal-based chase. Flat and spring washers are needed to prevent the screw loosening. Always use the appropriate torque setting of the power screwdriver to mount screws.

Thermal film such as T-gon is required between the bottom of the amplifier and top of the metal-based chase for maximum heat dissipation.
