



Key Features



- 1.7 ~ 2.2 GHz
- 0.90 dB Noise Figure
- 31.0 DBm Output IP₃
- 29.0 dB Gain
- +/-0.50 dB Gain Flatness
- 16.0 dBm P_{1dB}
- 1.35:1 VSWR
- Single Power Supply
- >34 Years MTBF
- Unconditional Stable
- RoHS Compliant

Product Description

WEA106 integrates WanTcom proprietary low noise amplifier technology, high frequency micro electronic assembly techniques, and high reliability design to realize optimum low noise figure, wideband, high linearity, and unconditional stable performances together. With single +5.0V DC operation, the amplifier has optimal input and output matching in the specified frequency range at 50-Ohm impedance system. The amplifier has standard SMA connectorized WP-10E gold plated housing.

The amplifier is designed to meet the rugged standard of MIL-STD-202.

Applications

- Mobile Infrastructures
- GPS
- 3G
- PCS
- Security System
- Measurement
- Fixed Wireless



Specifications

Summary of the electrical specifications WEA106 at room temperature

Index	Testing Item	Symbol	Test Constraints	Min	Nom	Max	Unit
1	Gain	S ₂₁	1.7 – 2.2 GHz	27	29	31	dB
2	Gain Variation	ΔG	1.7 – 2.2 GHz		+/- 0.5	+/-1.0	dB
3	Input VSWR	SWR ₁	1.7 – 2.2 GHz		1.35:1	1.5:1	Ratio
4	Output VSWR	SWR ₂	1.7 – 2.2 GHz		1.35:1	1.5:1	Ratio
5	Reverse Isolation	S ₁₂	1.7 – 2.2 GHz	40			dB
6	Noise figure	NF	1.7 – 2.2 GHz		0.9	1.2	dB
7	Output Power 1dB compression Point	P _{1dB}	1.7 – 2.2 GHz	13	16		dBm
8	Output-Third-Order Interception point	IP ₃	Two-Tone, P _{out} +0 dBm each, 1 MHz separation	28	31		dBm
9	Current Consumption	I _{dd}	V _{dd} = +5 V		95		mA
10	Power Supply Voltage	V _{dd}		+4.7	+5	+5.3	V
11	Thermal Resistance	R _{th,c}	Junction to case			220	°C/W
12	Operating Temperature	T _o		-40		+85	°C
13	Maximum Average RF Input Power	P _{IN, MAX}	DC – 6 GHz			5	dBm

Absolute Maximum Ratings

Parameters	Units	Ratings
DC Power Supply Voltage	V	6.0
Drain Current	mA	100
Total Power Dissipation	mW	500
RF Input Power	dBm	5
Channel Temperature	°C	150
Storage Temperature	°C	-55 ~ 125
Operating Temperature	°C	-40 ~ 85
Thermal Resistance	°C/W	220

Operation of this device above any one of these parameters may cause permanent damage.

Functional Block Diagram

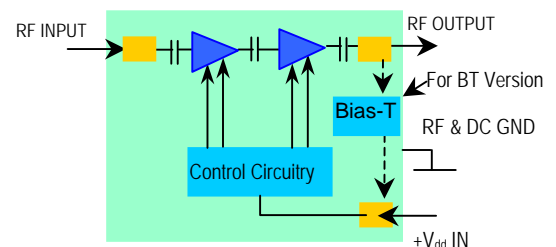

Ordering Information

Model Number	Feature
WEA106	Without Bias-T at Output
WEA106BT	With Bias-T at Output

Specifications and information are subject to change without notice.



Typical Data

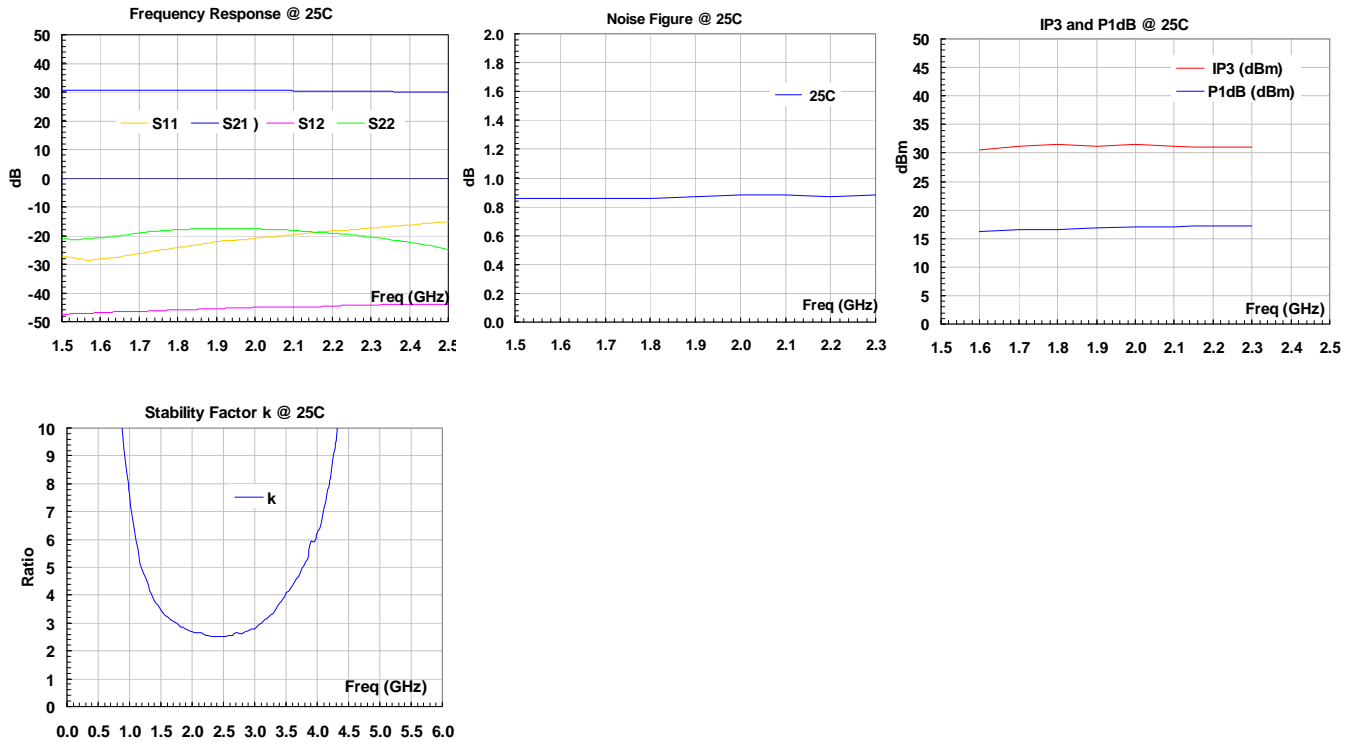

Outline, WP-10E Housing

UNITS: INCH
[mm]
BODY: Brass
Finish: Gold Plating
RF Connector: SMA F Gold
V_{dd} PWR: Feed through

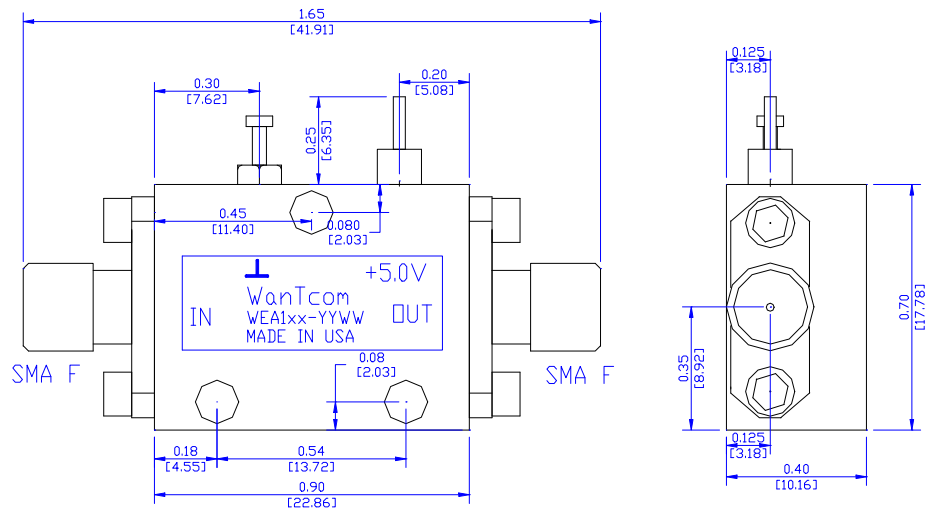

Specifications and information are subject to change without notice.



Application Notes:

SMA Torque Wrench Selection

Always use a torque wrench with 5 ~ 6 inch-lb coupling torque setting for mating the SMA cable connectors to the amplifier connectors. Never use torque more than 8 inch-lb wrench for tightening the mating cable connectors to the amplifier connectors. Otherwise, the permanent damage may occur to the SMA connectors of the amplifier. 8710-1582 (5 inch-lb) wrench from Agilent Technology is one of the ideal example.

DC Power Line Connection

Strip the insulation layer at the end of DC power supply wire. The stripped distance should be in the range of 0.100" to 0.200". The 24 ~ 26 American Wire Gauge wire is suitable. Wound the stripped terminal wire about 1 turn on the DC feed thru center pin. Solder the wounded wire and the center pin together. Clean the soldering area by Q-tip with alcohol to remove the flux and residue.

Repeat the process to solder the DC return wire on the ground turret. It is always helpful to use different color wires for DC wire and ground wire, such as red and black one.

Mounting the Amplifier

Use three pieces of #4-40 with longer than 9/16" screws for mounting the amplifier on a metal-based chase. Flat and spring washers are needed to prevent the screw loosening during the shock and vibration. Always use the appropriate torque setting of the power screwdriver to mount them.
