



WHM0104AE

100 - 400 MHz WIDE BAND 2 WATTS AMPLIFIER

REV C
February 2017

Key Features



- 100 ~ 400 MHz
- 3.2 dB Noise Figure
- 43.0 dBm Output IP₃
- 17.0 dB Gain
- +/-0.2 dB Gain Flatness
- 32 dBm P_{1dB}
- 1.5:1 VSWR
- Surface Mount Package
- >68 Years MTBF
- RoHS Compliant
- MSL-1 Moisture Sensitivity Level

Product Description

WHM0104AE is integrated with WanTcom proprietary low noise amplifier technologies, high frequency micro electronic assembly techniques, and high reliability designs to realize optimum low noise figure, wideband, and high performances together. The amplifier has optimal input and output matching in the specified frequency range at 50-Ohm impedance system. The amplifier has standard 0.40" x 0.20" x 0.085" surface mount package.

The amplifier is designed to meet the rugged standard of MIL-STD-883g.



Applications

- Mobile Infrastructures
- VHF
- CATV/DBS
- Defense
- Security System
- Measurement
- Fixed Wireless



Specifications

Summary of the key electrical specifications at room temperature

Index	Testing Item	Symbol	Test Constraints	Min	Nom	Max	Unit
1	Gain	S ₂₁	100 – 400 MHz	16	17.0	18	dB
2	Gain Variation	ΔG	100 – 400 MHz		+/-0.2		dB
3	Input VSWR	SWR ₁	100 – 400 MHz			2:1	Ratio
4	Output VSWR	SWR ₂	100 – 400 MHz			1.8:1	Ratio
5	Reverse Isolation	S ₁₂	100 – 400 MHz		30		dB
6	Noise Figure	NF	100 – 400 MHz		3.3		dB
7	Output Power 1dB Compression Point	P _{1dB}	100 – 400 MHz, V _{dd} = 10.0V, I _{dd} = 400 mA	31	32		dBm
8	Output-Third-Order Interception Point	IP ₃	Two-Tone, P _{out} = 20 dBm each, 1 MHz separation	42			dBm
9	Current Consumption	I _{dd}	V _{dd} = +10.0 V		400		mA
10	Power Supply Voltage, Positive	V _{dd}		+9	+10	+12	V
11	Power Supply Voltage, Negative	V _{gg}	For normal operation	-2.5	-1.5	-0.5	V
12	Thermal Resistance	R _{th,c}	Junction to case			18	°C/W
13	Operating Temperature	T _o		-40		+85	°C
14	Maximum RF CW Input Power	P _{IN, MAX}	DC – 6.0 GHz			20	dBm

Absolute Maximum Ratings

Parameters	Units	Ratings
DC Power Supply Voltage	V	12
Drain Current	mA	500
Total Power Dissipation	W	4.5
RFCW Input Power	dBm	20
Channel Temperature	°C	160
Storage Temperature	°C	-65 ~ 150
Operating Temperature	°C	-40 ~ +85

Operation beyond any one of these parameters may cause permanent damage.

Ordering Information

Model Number	WHM0104AE
--------------	-----------

ESD resistant tube with the capacity of 10 pieces is used for the packing. Contact factory for tape and reel packing option for higher volume order.

Specifications and information are subject to change without notice.

Block Diagram

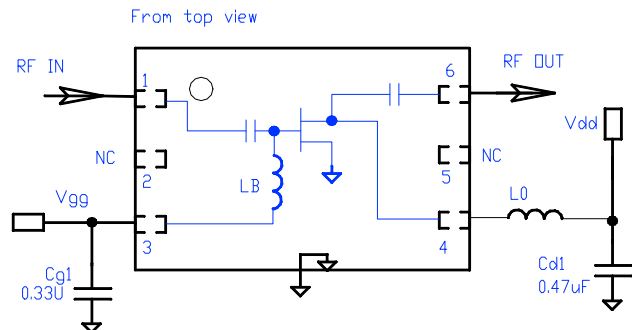

Important: Sequencing bias circuit required to V_{gg} and V_{dd}!
Adjust V_{gg} for the specified DC bias current



Typical Data

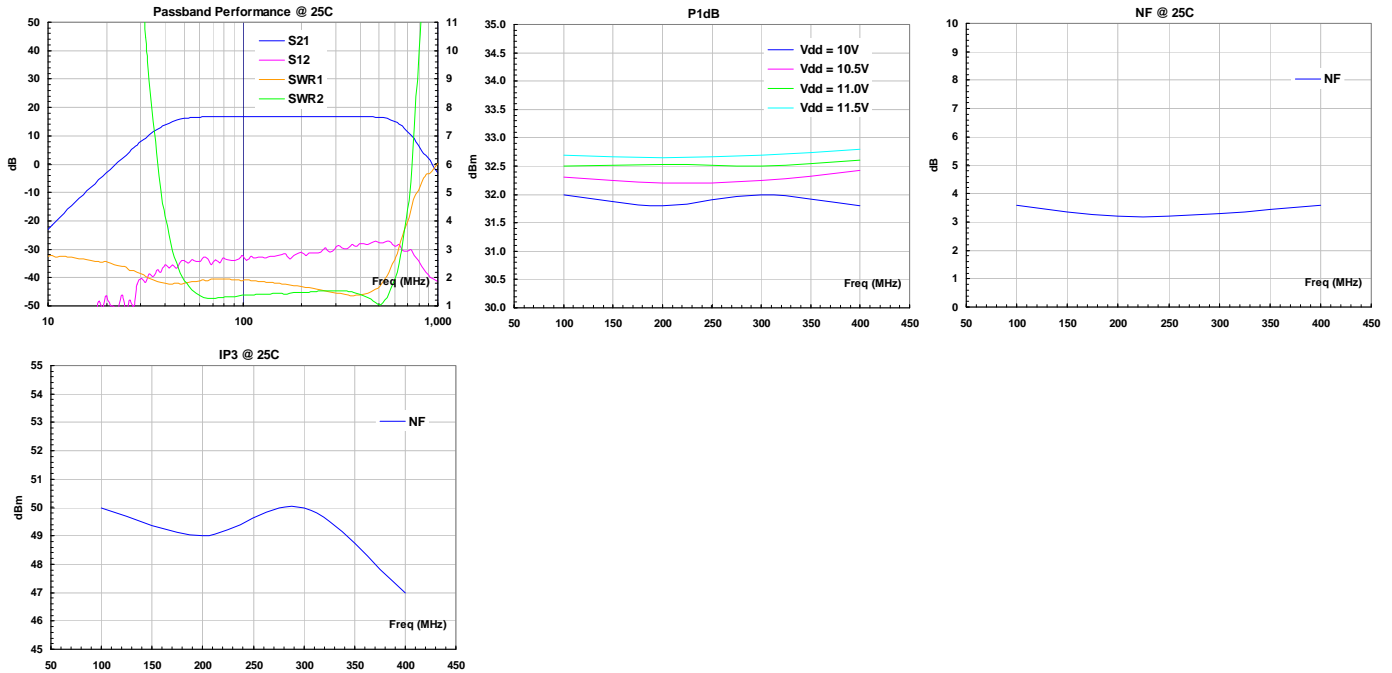

Outline and Foot Print, WHM-3

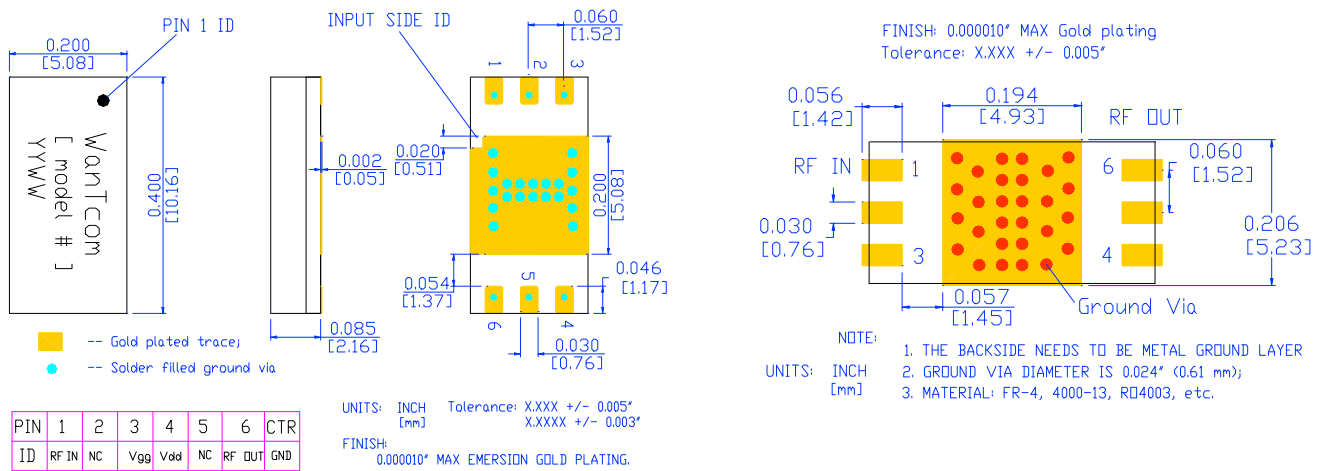

Fig. 1 (a)

Outline

(b)

Footprint

Specifications and information are subject to change without notice.



Application Notes:

A. Motherboard Layout/Footprint

The recommended motherboard layout is shown in **Fig. 1, (b)**. Sufficient numbers of ground vias on the motherboard are essential for the RF grounding and thermal dissipation. Solder filled vias are recommended for maximum heat dissipation purpose. The width of the 50-Ohm microstrip lines at the input and output RF ports may be different for different property of the substrate. The ground plane is needed to connect the center ground pad of the device through the ground vias. The ground plane is also essential for the 50-Ohm microstrip line launches at the input and output ports.

B. DC Bias Sequence

Always bias the V_{gg} of the negative voltage first at Pin 3 before applying V_{dd} at Pin 4 through an RF choke. Always disconnect V_{dd} first before disconnecting V_{gg} .

C. L0, the RF choke

L0, the RF choke at the V_{dd} path, needs to have the DC current rating of better than 1.5 time of the specified operating DC current and the parasitic resonance free inside the passband.

D. Assembly

The regular low temperature and no clean flux solder paste such as SN63Pb37 is recommended. The high temperature solder has been used for the WHM series amplifier internal assembly itself. The melting temperature point of the high temperature solder is around 230 °C. Thus, melting temperature of the solder paste should be below 220 °C for assembling WHM series amplifier on the test board to reduce the possible damage. The temperature melting point of the SN63Pb37 solder paste is around 183 °C and is suitable for the assembly purpose. For RoHS assembly process, Sn60Bi40 low temperature solder paste is required. Regular SAC305 RoHS reflow process will damage the amplifier.

The SN63Pb37 solder paste can be dispensed by a needle manually or driven by a compressed air. **Fig. 2** shows the example of the bare test board, the dispensed solder paste pattern, and the placed WHM0715AE on the test board. Each solder paste dot is in about diameter of 0.005" ~ 0.010" (0.125 ~ 0.250 mm).

For higher volume assembly, a production solder paste stencil with 0.006" (0.15 mm) is recommended to print the solder paste on the circuit board.

For more detail assembly process, refer to AN-109 at www.wantcominc.com website.

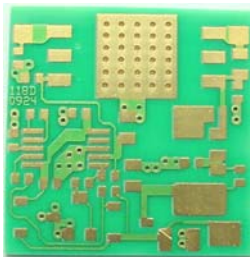
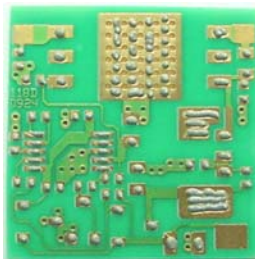

Fig. 2 (a)



(b)



(c)

E. Heat Sink

Sufficient heat sink is required. The assembled part shall be mounted on a heat sink securely. Thermal compound is needed between the heat sink surface and the backside of the motherboard of the assembly.
