



WHM0206AE

200 - 600 MHz LOW NOISE WIDE BAND AMPLIFIER

REV C
February 2018

Key Features



- 200 – 600 MHz
- 1.5 dB Noise Figure
- 34.0 dBm Output IP₃
- 21.0 dB Gain
- +/-0.5 dB Gain Flatness
- 24.0 dBm P_{1dB}
- 1.5:1 VSWR Fully Matched
- Single Power Supply
- >68 Years MTBF
- RoHS Compliant
- MSL-1 Moisture Sensitivity Level

Product Description

WHM0206AE is integrated with WanTcom proprietary low noise amplifier technologies, high frequency microelectronics assembly techniques, and high reliability designs to realize optimum low noise figure, wideband, and high performances together. With single +5.0V DC low power operation, the amplifier has optimal input and output matching in the specified frequency range at 50-Ohm impedance system. The amplifier has standard 0.35" x 0.25" x 0.08" surface mount package.

The amplifier is designed to meet the rugged standard of MIL-STD-883g.

CAUTION:



ELECTROSTATIC DISCHARGE SENSITIVE

Applications

- Mobile Infrastructures
- VHF & UHF
- Broadcast
- Security System
- Measurement
- Fixed Wireless



Specifications

Summary of the key electrical specifications at room temperature

Index	Testing Item	Symbol	Test Constraints	Min	Nom	Max	Unit
1	Gain	S ₂₁	200 – 600 MHz		21		dB
2	Gain Variation	ΔG	200 – 600 MHz		+/-0.5	+/-1.2	dB
3	Input Return Loss	S ₁₁	200 – 600 MHz	10	14		dB
4	Output Return Loss	S ₂₂	200 – 600 MHz	10	14		dB
5	Reverse Isolation	S ₁₂	200 – 600 MHz		20		dB
6	Noise Figure	NF	200 – 600 MHz		1.0	1.5	dB
7	Output 1dB Gain Compression Point	P _{1dB}	200 – 600 MHz	23	24		dBm
8	Output-Third-Order Interception Point	IP ₃	Two-Tone, P _{out} = 0 dBm each, 1 MHz separation		34		dBm
9	Current Consumption	I _{dd}	V _{dd} = +5 V		140		mA
10	Power Supply Operating Voltage	V _{dd}		+4.7	+5.0	+5.3	V
11	Thermal Resistance	R _{th,c}	Junction to case			110	°C/W
12	Operating Temperature	T _o		-40		+85	°C
13	Maximum Input CW RF Power	P _{IN,MAX}	DC – 6.0 GHz			13	dBm

Absolute Maximum Ratings

Parameters	Units	Ratings
DC Power Supply Voltage	V	7.0
Drain Current	mA	180
Total Power Dissipation	mW	500
RF Input Power	dBm	13
Junction Temperature	°C	150
Storage Temperature	°C	-65 ~ 150
Operating Temperature	°C	-54 ~ +100
Thermal Resistance	°C/W	220

Operation of this device beyond any one of these parameters may cause permanent damage.

Functional Block Diagram

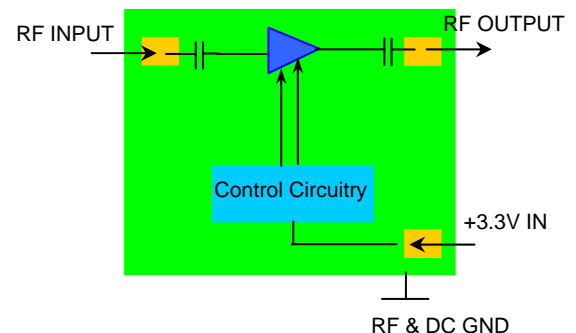

Ordering Information

Model Number	WHM0206AE
--------------	-----------

ESD resistance tube of 25 pieces is used for the packing. Contact factory for tape and reel packing option for higher volume order.

Specifications and information are subject to change without notice.



WHM0206AE

200 - 600 MHz LOW NOISE WIDE BAND AMPLIFIER

REV C
February 2018

Typical Data

Preliminary



Outline, WHM-5

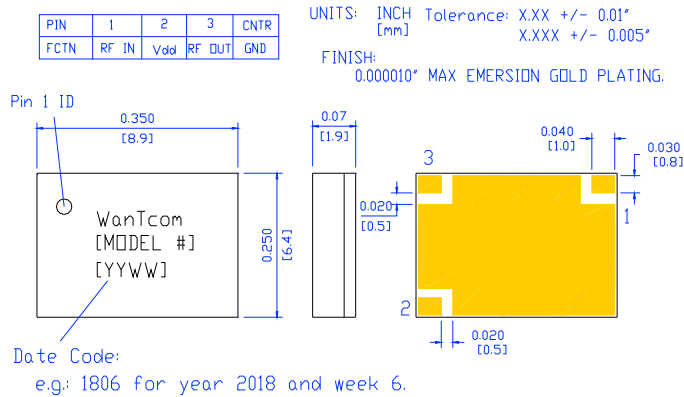

Foot Print

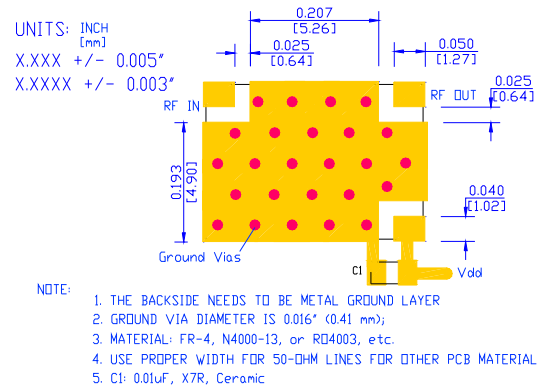

Application Notes:

A. Motherboard Layout

The recommended demo layout is shown in **Figure 1**. Sufficient numbers of ground vias on the center paddle are essential for the RF grounding. The width of the 50-Ohm microstrip lines at the input and output RF ports may be different for different property of the PCB substrate. The ground plane on the backside of the PCB substrate is needed to connect the center ground pad through the ground vias. The ground plane is also essential for the 50-Ohm microstrip line at the input and output ports.

The +5V DC voltage is applied to Pin 2. For +5V line trace length being longer than 6 inches without a decoupling capacitor, a 0.10 uF de-coupling capacitor, C₁, with minimum rating voltage of 10V is needed across the +5V pin to ground. The capacitor must be rated in the temperature range of -55 °C to 100 °C to ensure the entire circuit work in the specified temperature range.

No DC block capacitor is required at input and output RF ports. The amplifier has built-in DC block capacitors at the ports.

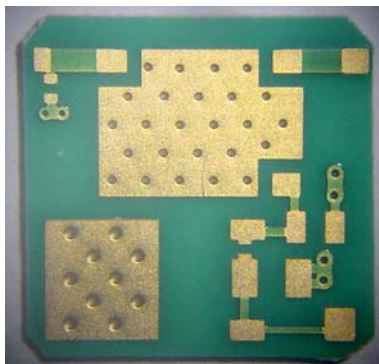

Fig. 1 Motherboard

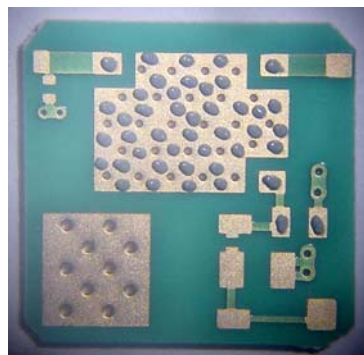

Fig. 2 Dispensed solder paste

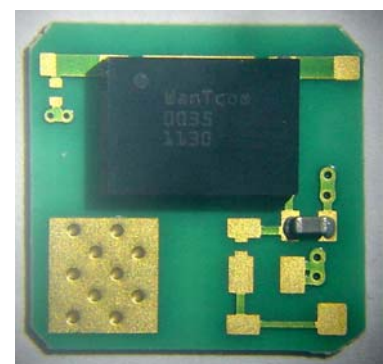

Fig. 3 Assembled part

B. Assembly

The regular low temperature and no clean solder paste such as SN63Pb37 is recommended. The high temperature solder has been used internally for the WHM series amplifier assembly. The melting temperature point of the high temperature solder is around 240 °C. Thus, melting temperature of the solder paste should be below 220 °C for assembling the amplifier on the test board to reduce the possible damage, taking into account the reflow oven temperature fluctuation. The temperature melting point of the SN63Pb37 solder paste is around 183 °C and is suitable for the assembly purpose. For RoHs reflow process, regular SAC305 solder reflow profile does not suitable for the LNA due to the peak reflow temperature can be as high as 250

Specifications and information are subject to change without notice.



$^{\circ}\text{C}$, which will damage the amplifier permanently. Sn60Bi40 RoHS low temperature solder paste is suitable for the RoHS assembly requirement.

The solder paste can be dispensed by a needle manually or driven by a compressed air source. **Figure 2** shows the example of the dispensed solder paste pattern. Each solder paste dot is in the diameter of 0.005" ~ 0.010" (0.125 ~ 0.250 mm) range.

For volume assembly, a stencil with 0.004" to 0.006" (0.10 mm to 0.15 mm) thickness is recommended to print the solder paste on the circuit board.

Figure 3 illustrates the assembled LNA on the motherboard.

For more detail assembly process, refer to AN-109 at www.wantcominc.com website.

C. Electrical Testing and Fine Tuning

The amplifier is designed to be fully matched at the input and output ports. Any tuning is not needed. However, when connecting the assembled amplifier to a device such as a SMA connector or a filter, the connecting points or joint points could affect mainly the return losses at the ports due to the non-ideal 50-Ohm impedance of the devices connected to the amplifier. By varying the connection feature size such as the solder amount to get the optimum return losses or best matching result at the interface. This fine-tuning has little effect on the other performance such as gain, noise figure, P_{1dB} , or IP_3 .

During the fine-tuning process, a vector network analyzer can be used to monitoring the return losses at the ports while varying the feature size of the joint points. Varying the connection feature size until the optimum return losses are achieved.
