



# WHM0526AE

## 0.5- 2.5 GHz LOW NOISE WIDE BAND AMPLIFIER

REV C  
January, 2010

### Key Features



- 50 Ohm Impedance
- 0.5 ~ 2.5 GHz
- 0.8 ~ 1.0 dB Noise Figure
- 34.0 dBm Output IP<sub>3</sub>
- 14 ~ 20 dB Gain
- 16.0 Minimum dBm P<sub>1dB</sub>
- 1.45:1 VSWR Fully Matched
- Single Power Supply
- >300 Years MTBF
- RoHS Compliance
- MSL-1 Moisture Sensitivity Level

### Product Description

WHM0526AE is integrated with WanTcom proprietary low noise amplifier technologies, high frequency micro electronic assembly techniques, and high reliability designs to achieve optimum low noise figure, wideband, and high performances together. With single +3.0V DC operation, the amplifier has optimal input and output matching in the specified frequency range at 50-Ohm impedance system. The amplifier has standard 0.25" x 0.25" x 0.065" surface mount package.

The amplifier is designed to meet the rugged MIL-STD-883g standard.



### Applications

- Mobile Infrastructures
- GPS
- WiMAX
- Defense
- Security System
- Measurement
- Fixed Wireless
- Avionics

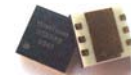

### Specifications

Summary of the key electrical specifications at room temperature

Index	Testing Item	Symbol	Test Constraints	Min	Nom	Max	Unit
1	Gain	S <sub>21</sub>	0.5 – 2.5 GHz	13.8	16	21	dB
2	Gain Variation	ΔG	0.5 – 2.5 GHz		+/-3.5		dB
3	Input Return Loss	S <sub>11</sub>	0.5 – 2.5 GHz	14	16		dB
4	Output Return Loss	S <sub>22</sub>	0.5 – 2.5 GHz	14	16		dB
5	Reverse Isolation	S <sub>12</sub>	0.5 – 2.5 GHz	15			dB
6	Noise Figure	NF	0.5 – 2.5 GHz	0.7	0.8	1.1	dB
7	Output Power 1dB Compression Point	P <sub>1dB</sub>	0.5 – 2.5 GHz	16	18		dBm
8	Output-Third-Order Interception Point	IP <sub>3</sub>	Two-Tone, P <sub>out</sub> = 0 dBm each, 1 MHz separation	31	34		dBm
9	Current Consumption	I <sub>dd</sub>	V <sub>dd</sub> = +3.0 V		65		mA
10	Power Supply Operating Voltage	V <sub>dd</sub>		+2.8	+3	+3.2	V
11	Thermal Resistance	R <sub>th,c</sub>	Junction to case			215	°C/W
12	Operating Temperature Range	T <sub>o</sub>		-40		+85	°C
13	Maximum Input CW RF Power	P <sub>IN, MAX</sub>	DC – 6.0 GHz			10	dBm

### Absolute Maximum Ratings

Parameters	Units	Ratings
DC Power Supply Voltage	V	-0.5 ~ +7.0
Drain Current	mA	80
Total Power Dissipation	mW	400
Input CW RF Power	dBm	10
Channel Temperature	°C	150
Storage Temperature	°C	-65 ~ 150
Operating Temperature	°C	-55 ~ +100
Thermal Resistance	°C/W	215

Operation of this device beyond any one of these parameters may cause permanent damage.

### Ordering Information

Model Number	WHM0526AE
--------------	-----------

ESD tube with the capacity of 25 pieces is used for the packing. Contact factory for tape and reel packing option for higher volume order.

### Functional Block Diagram

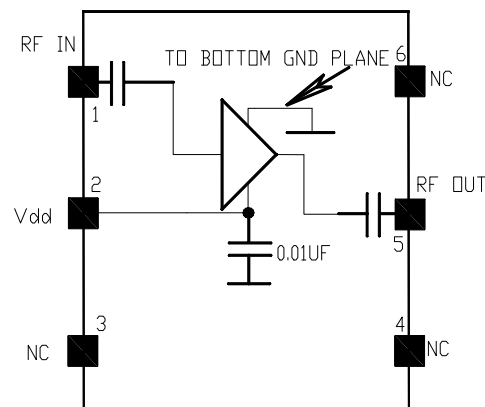

Specifications and information are subject to change without notice.



# WHM0526AE

## 0.5- 2.5 GHz LOW NOISE WIDE BAND AMPLIFIER

REV C  
January, 2010

### Typical Data

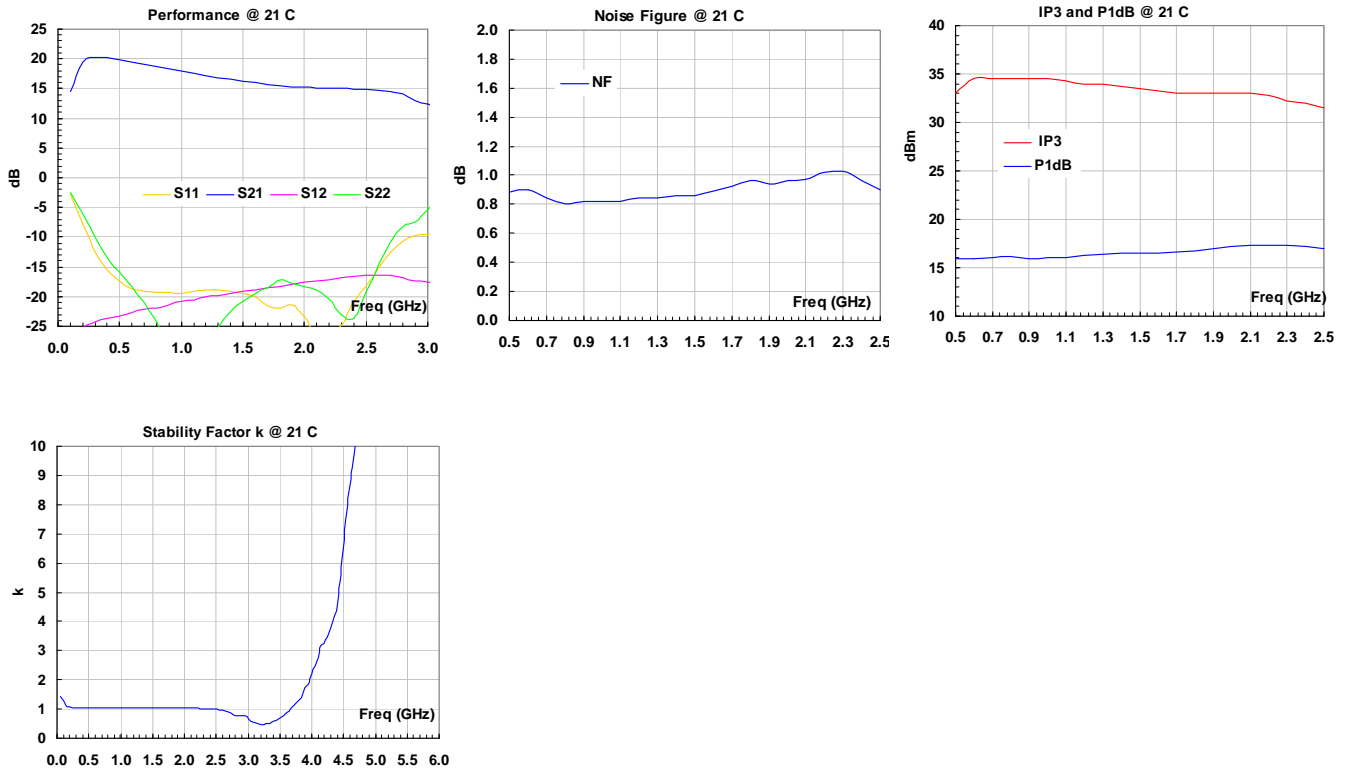

### Outline, WHM-1S

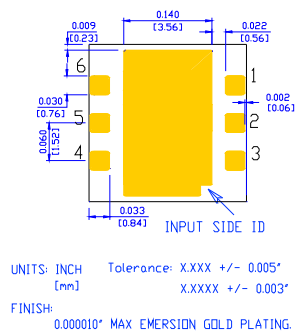
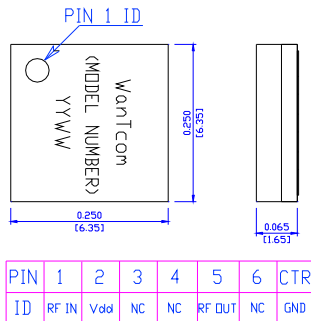

### Foot Print/Motherboard Layout

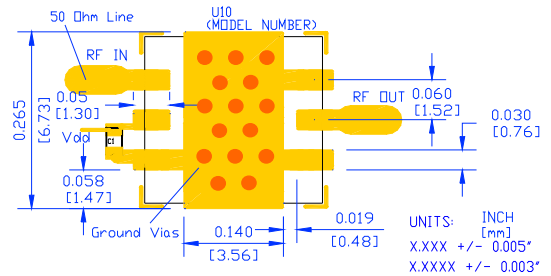

- NOTE:
1. THE BACKSIDE NEEDS TO BE METAL GROUND LAYER
  2. GROUND VIA DIAMETER IS 0.024" (0.61 mm);
  3. C1 IS 0.01 UF OR LARGER VALUE CAPACITOR
  4. MATERIAL: FR-4, 4000-13, FRDM NELCO
  5. USE PROPER WIDTH FOR 50-OHM LINES FOR OTHER PCB MATERIAL

Specifications and information are subject to change without notice.



### Application Notes:

#### A. Motherboard Layout

The recommended motherboard layout is shown in **Figure 1**. Sufficient numbers of ground vias on center ground pad are essential for the RF grounding. The width of the 50-Ohm microstrip lines at the input and output RF ports may be different property of the substrate. The ground plane on the backside of the substrate is needed to connect the center ground pad through the vias. The ground plane is also essential for the 50-Ohm microstrip line launches at the input and output ports.

The +3V DC voltage is applied at Pin 2. For +3V line trace length being longer than 6 inches without a decoupling capacitor, a 0.1 uF de-coupling capacitor,  $C_1$ , with minimum rating voltage of 10V is needed across the +3V pin to ground. The capacitor must be rated in the temperature range of  $-55^{\circ}\text{C}$  to  $100^{\circ}\text{C}$  to ensure the entire circuit work in the specified temperature range.  $C_1$  needs to locate very close to Pin 2 to eliminate the possible RF input signal loss due to the coupling between Pin 1 and Pin 2. Failing to do that may cause 0.10 dB to 0.20 dB additional loss at the input port and thus the noise figure will increase at that amount. For +5V voltage operation, a series resistor or pull-up resistor, 33 Ohm/0.25W, is needed to lower the +5V to +3V.

No DC block capacitor is required at input and output RF ports. The NC pins connected to ground are recommended.

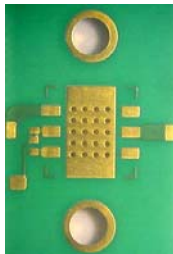

Fig. 1 Motherboard foot print

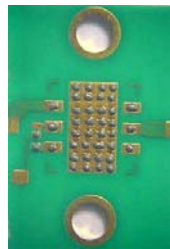

Fig. 2 Dispensed solder paste

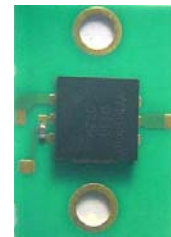

Fig. 3 Assembled part

#### B. Assembly

The regular low temperature and none clean solder paste such as SN63/Pb37 is recommended. The high temperature solder has been used internally for the WHM series amplifier assembly. The melting temperature point of the high temperature solder is around  $240^{\circ}\text{C}$ . Thus, melting temperature of the solder paste should be below  $220^{\circ}\text{C}$  for assembling WHM series amplifier on the test board to reduce the possible damage. The temperature melting point of the SN63/Pb37 solder paste is around  $183^{\circ}\text{C}$  and is suitable for the assembly purpose.

The SN63/Pb37 solder paste can be dispensed by a needle manually or driven by a compressed air. **Figure 2** shows the example of the dispensed solder paste pattern. Each solder paste dot is in the diameter of  $0.005'' \sim 0.010''$  ( $0.125 \sim 0.250$  mm).

For volume assembly, a stencil with  $0.004''$  ( $0.10$  mm) is recommended to print the solder paste on the circuit board.

For more detail assembly process, refer to AN-109 at [www.wantcominc.com](http://www.wantcominc.com) website.

#### C. Electrical Testing and Fine Tuning

The amplifier is designed to be fully matched at the input and output ports. Any tuning is not needed. However, when connecting the assembled amplifier to a device such as a SMA connector or a filter, the connecting point or joint point could affect mainly the return loss at the port due to the non-ideal 50-Ohm impedance of the device. By varying the connection feature size such as the solder amount to get the optimum return loss or best matching result at the interface. This fine-tuning has little affect on the other performance such as gain, noise figure,  $P_{1dB}$ , or  $IP_3$ .

During the fine-tuning process, a vector network analyzer can be used to monitoring the return loss at the port while varying the feature size of the joint point. Varying the connection feature size until the optimum return loss is achieved.

\*\*\*\*\*

Specifications and information are subject to change without notice.