



WZA304

0.5 – 2.5 GHz LOW NOISE WIDE BAND AMPLIFIER

REV A
May 2011

Key Features

- 0.5 ~ 2.5 GHz
- 0.9 dB noise figure
- 27.0 dBm output IP₃
- 30.0 dB Gain
- 14.0 dBm P_{1dB}
- 1.3:1 VSWR
- Single Power Supply
- RoHS Compliant
- **MADE IN USA**



Applications

- Mobile Infrastructures
- GPS
- Avionics
- Measurement
- Fixed Wireless



Absolute Maximum Ratings

Parameters	Units	Rating
DC Power Supply Voltage	V	6.0
Drain Current	mA	70
Total Power Dissipation	mW	300
RF Input Power	dBm	10
Channel Temperature	°C	150
Storage Temperature	°C	-55~125
Operating Temperature	°C	-40~85
Thermal Resistance	°C/W	220

Operation of this device above any one of these parameters may cause permanent damage.

Specifications

Summary of the electrical specifications WZA304 at room temperature

Index	Testing Item	Symbol	Test Constraints	Min	Nom	Max	Unit
1	Gain	S ₂₁	0.5 – 2.5 GHz		30		dB
2	Gain Variation	ΔG	0.5 – 2.5 GHz			+/- 3.0	dB
3	Input VSWR	SWR ₁	0.5 – 2.5 GHz		1.3:1	1.5:1	Ratio
4	Output VSWR	SWR ₂	0.5 – 2.5 GHz		1.3:1	1.5:1	Ratio
5	Reverse Isolation	S ₁₂	0.5 – 2.5 GHz		45		dB
6	Noise figure	NF	0.5 – 2.5 GHz		0.9	1.2	dB
7	Output Power 1dB compression Point	P _{1dB}	0.5 – 2.5 GHz		14		dBm
8	Output-Third-Order Interception point	IP ₃	Two-Tone, P _{out} = 0 dBm each, 1 MHz separation	24	27		dBm
9	Current Consumption	I _{dd}	@ 25 °C		50		mA
10	Power Supply Voltage	V _{dd}		+4.7	+5.0	+5.3	V
11	Thermal Resistance	R _{th,c}	Junction to case			220	°C/W
12	Operating Temperature	T _o	Case temperature at the bottom of the housing	-40		+85	°C
13	Maximum Average RF Input Power	P _{IN,MAX}	DC – 13 GHz			10	dBm
14	Spurious	P _{spur}	DC – 13 GHz	-70			dBc

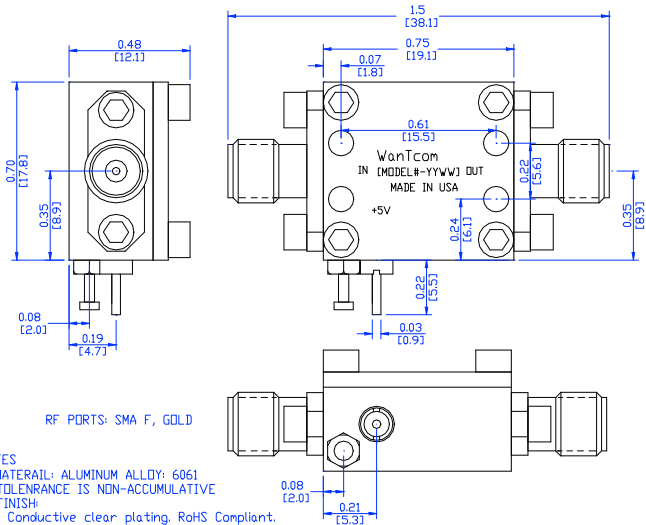
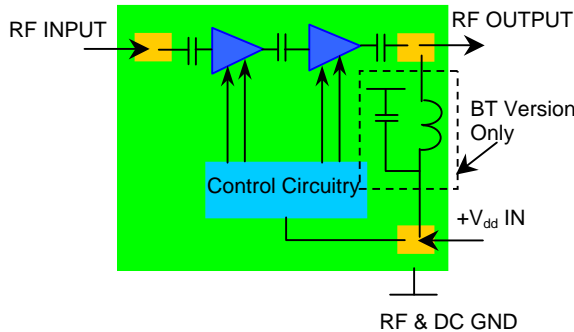

Ordering Information

Function	No Bias-T	With Bias-T
Model Number	WZA304	WZA304BT

Outline, WP-30 Housing

Specifications and information are subject to change without notice.



Typical Performance

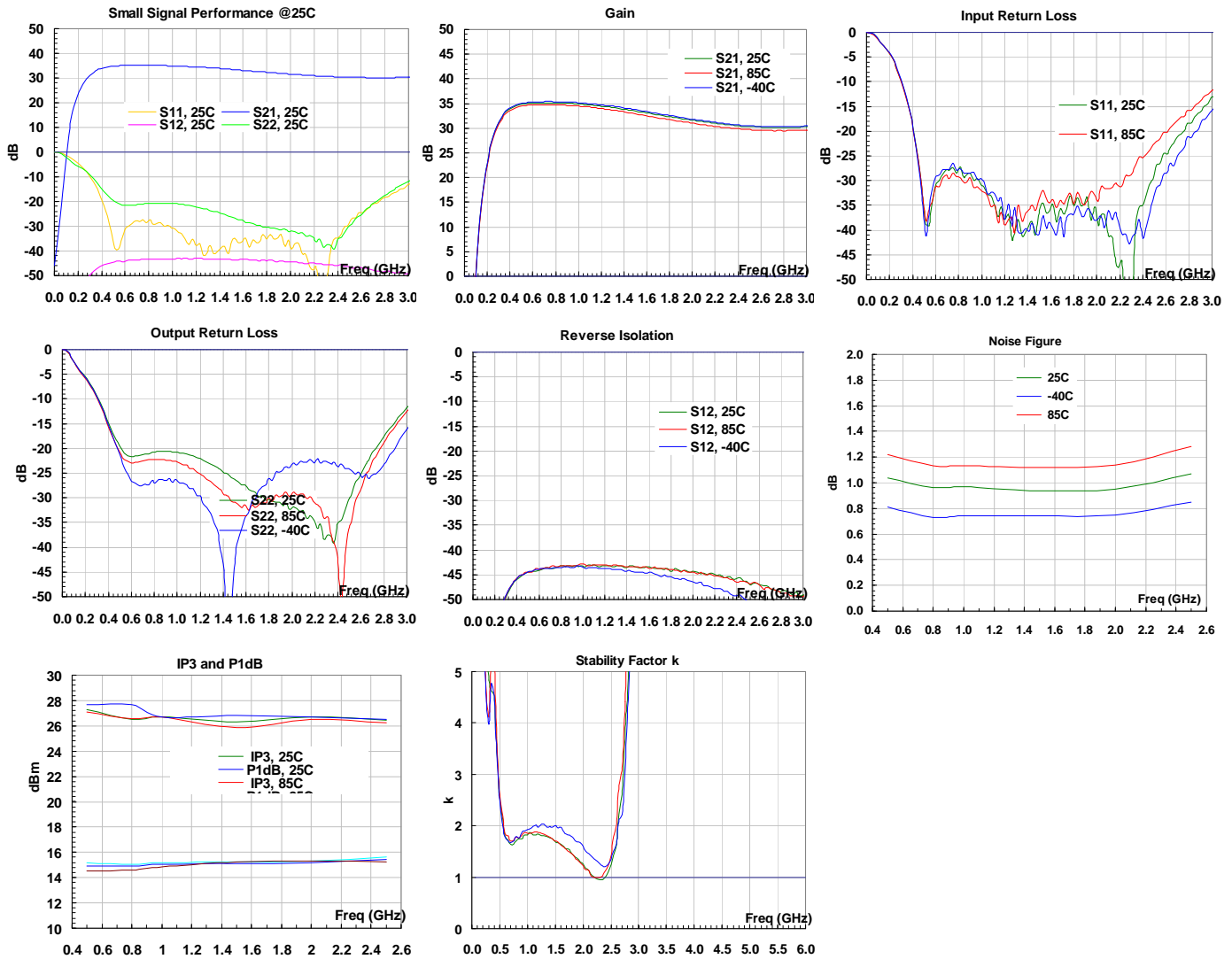

Application Notes:

A. SMA Torque Wrench Selection

Always use a torque wrench with 5 ~ 6 inch-lb coupling torque setting for mating the SMA cables to the amplifier. Never use torque more than 8 inch-lb wrench for tightening the mating cable to the connector. Otherwise, the permanent damage will occur to the SMA connectors of the amplifier. 8710-1582 (5 inch-lb) is one of the ideal torque wrench choice from Agilent Technology.

B. Mounting the Amplifier

Use three pieces of #2-56 with longer than 9/16" screws for mounting the amplifier on a metal-based chase. Flat and spring washers are needed to prevent the screw loosening during the shock and vibration. Always use the appropriate torque setting of the power screwdriver to mount them.

Specifications and information are subject to change without notice.