



0.82 - 0.98 GHz LOW NOISE AMPLIFIER WLA08-4030A¹

WLA08-4030A is a low noise figure, wideband, and high linear amplifier. The amplifier offers typical 0.50 dB noise figure and 31 dBm output IP₃ at the frequency range from 0.82 GHz to 0.98 GHz of UHF, Cellular, and GSM bands.

WLA08-4030A is most suitable for cellular base stations, wireless data communications, tower top receiver amplifiers, last-mile wireless communication systems, and wireless measurement applications. WLA08-4030A can be configured with built-in bias-T for remote 5 V DC power supply.

WLA08-4030A is designed to meet the rugged standards of MIL-STD-202.



Key Features:

Impedance:	50 Ohm
MTBF ² :	>300,000 hrs (34Years)
Unconditional Stable:	k>1
Low Noise:	0.50 dB
Output IP ₃ :	30.0 dBm
Gain:	40.0 dB
P _{1dB} :	16.0 dBm minimum
Single power supply:	100 mA @ +5V
Frequency Range:	0.82 ~ 0.98 GHz
Operating Temperature:	-40 ~ +85 °C
Return Losses:	20.0 dB
Small size:	SMA Female, 0.90" x 0.70" x 0.4" (41.9 mm x 17.8 mm x 10.2 mm) gold plated housing.
Built-in Functions:	DC blocks at input and output, temperature compensation circuits, and auto DC biases.

Absolute Maximum Ratings³:

Symbol	Parameters	Units	Absolute Maximum
V _{dd}	DC Power Supply Voltage	V	5.5
I _{dd}	Drain Current	mA	120
P _{diss}	Total Power Dissipation	mW	600
P _{In,Max}	RF Input Power	dBm	10
T _{ch}	Channel Temperature	°C	150
T _{STG}	Storage Temperature	°C	-65 ~ 150
T _{O,MAX}	Maximum Operating Temperature	°C	-55 ~ 100
R _{th,c}	Thermal Resistance	°C/W	220

¹ Specifications are subject to change without notice.

² MTBF: Mean Time Between Failure, Per TR-NWT-000332, ISSUE 3, SEPTEMBER, 1990, T=40°C

³ Operation of this device above any one of these parameters may cause permanent damage.



Specifications:

a) **Table 1** Summary of the electrical specifications WLA08-4030A at room temperature

Index	Testing Item	Symbol	Test Constraints	Nom (RT)	Min	Max	Unit
1	Gain	S_{21}	0.82 – 0.98 GHz	40			dB
2	Gain Variation	ΔG	0.82 – 0.98 GHz	+/- 0.5		+/- 1.0	dB
3	Input Return Loss	S_{11}	0.82 – 0.98 GHz	20	16		dB
4	Output Return Loss	S_{22}	0.82 – 0.98 GHz	20	16		dB
5	Reverse Isolation	S_{12}	0.82 – 0.98 GHz	52	50		dB
6	Noise figure	NF	0.82 – 0.98 GHz	0.50		0.65	dB
7	Output Power 1dB compression Point	P_{1dB}	0.82 – 0.98 GHz	18	16		dBm
8	Output-Third-Order Interception point	IP_3	Two-Tone, P_{out} +0 dBm each, 1 MHz separation	31	30		dBm
9	Current Consumption	I_{dd}	V_{dd} = +5 V	100			mA
10	Power Supply Voltage	V_{dd}		+5	+4.7	+5.3	V
11	Thermal Resistance	$R_{th,c}$	Junction to case			215	°C/W
12	Operating Temperature	T_o			-40	+85	°C
13	Maximum Average RF Input Power	$P_{IN, MAX}$	0.82 – 0.98 GHz			10	dBm

b) Passband Frequency Response

As shown in **Figure 1**, the typical gain of the WLA08-4030A is 40.0 dB across 0.82 GHz to 0.98 GHz frequency range. The typical input and output return losses are 20 dB across 0.82 GHz to 0.98 GHz frequency.

Figure 2 shows P_{1dB} and IP_3 of the WLA08-4030A. The typical P_{1dB} and IP_3 are 18.0 dBm and 31.0 dBm in the frequency range of 0.82 GHz to 0.98 GHz, respectively.

Figure 3 illustrates the noise figure performance. The noise figure is 0.60 dB across the frequency range of 0.82 GHz to 0.98 GHz. At 85 °C, WLA08-4030A only has 0.25 dB noise increases. At -40 °C, WLA08-4030A offers approximately 0.20 dB less noise figure than that at room temperature.

Figure 4 is the plot of the stability factor k of WLA08-4030A. The amplifier is unconditional stable at room temperature due to k is great than 1 at all frequency ranges.

Figure 5 is the internal block diagram of WLA08-4030A.

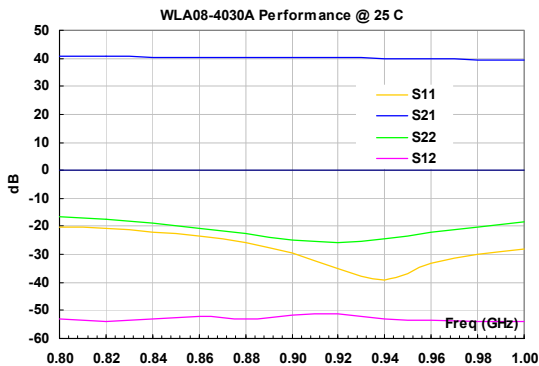

FIG. 1 Typical small signal performance.

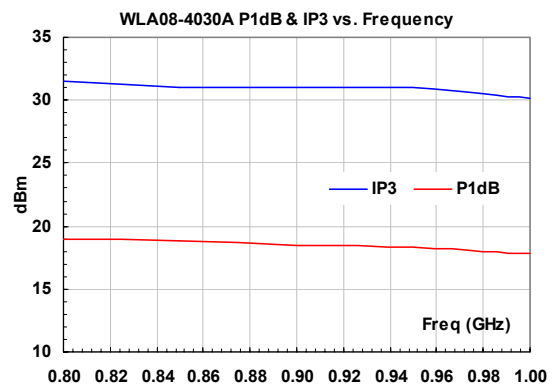

FIG. 2 Typical P_{1dB} and IP_3 at room temperature.

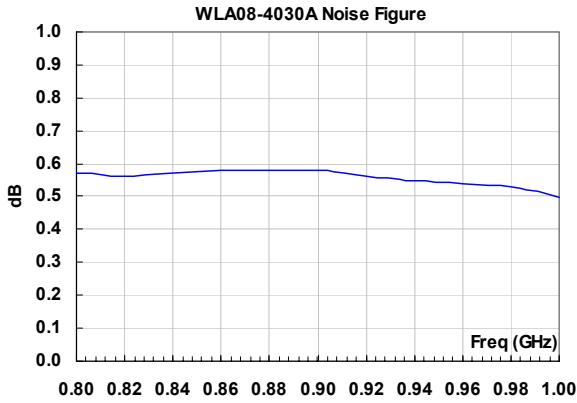

FIG. 3 Noise figure performance at room temperature

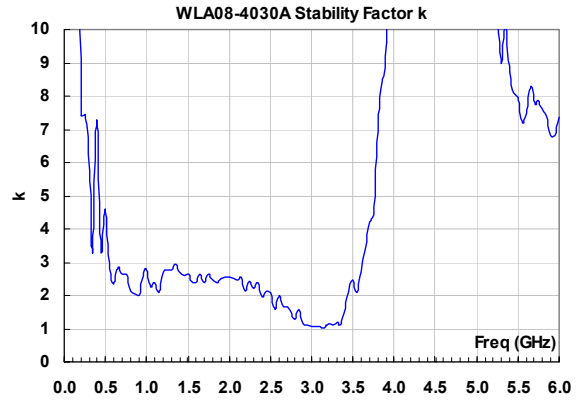

FIG. 4 Stability factor k of WLA08-4030A

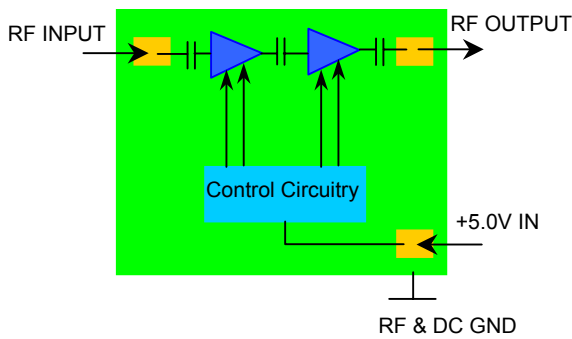

FIG. 5 Block diagram of WLA08-4030A

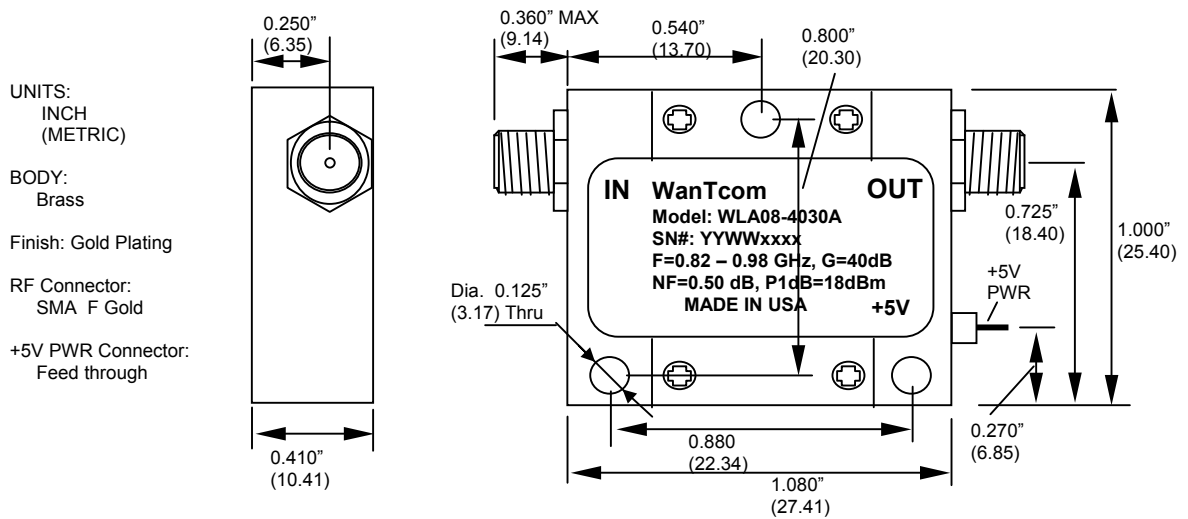

FIG. 6 WLA08-4030A outline



WLA08-4030A Mechanical Outline, WP-5:

Figure 6 shows the mechanical outline of WLA08-4030A. It is a WanTcom's standard WP-5 housing with gold plating. Both RF input and output ports are equipped with SMA female connectors and the DC port connector is an EMI filtered feed thru pin.

Ordering Information

Model Number	WLA08-4030A
---------------------	-------------

Small Signal S-Parameters:

!WLA08-4030A
Is-parameters at Vdd=5V, Idd=100mA. Last updated 8/15/02.

GHZ s MA R 50

IF(GHz)	MAG S11	ANG S11	MAG S21	ANG S21	MAG S12	ANG S12	MAG S22	ANG S22
0.05	0.12	-100.2	2.80	-155.6	0.0001	-75.6	0.60	149.9
0.1	0.12	141.2	14.06	169.6	0.0003	-141.3	0.31	100.7
0.2	0.53	14.7	94.26	100.5	0.0005	-150.2	0.09	16.9
0.3	0.27	-52.1	127.31	16.9	0.0006	-172.3	0.14	-96.8
0.4	0.15	-49.5	121.94	-26.4	0.0005	151.7	0.23	-139.3
0.5	0.15	-44.8	117.67	-58.6	0.0009	119.9	0.26	-168.1
0.6	0.15	-55.3	113.84	-86.4	0.0018	94.7	0.26	165.9
0.7	0.14	-71.7	111.29	-112.4	0.0016	93.3	0.22	139.2
0.8	0.10	-94.0	108.23	-137.4	0.0022	70.6	0.15	108.6
0.9	0.03	-114.7	103.34	-164.3	0.0026	62.1	0.06	28.8
1	0.04	6.3	91.18	168.1	0.0020	36.9	0.12	-88.1
1.1	0.09	-11.9	75.53	144.3	0.0027	52.6	0.22	-120.4
1.2	0.13	-34.5	61.46	124.3	0.0028	41.1	0.30	-141.3
1.3	0.13	-58.6	50.72	108.9	0.0031	28.5	0.36	-158.9
1.4	0.11	-77.6	43.29	97.5	0.0037	19.0	0.39	-175.3
1.5	0.09	-96.6	38.49	82.0	0.0041	21.3	0.41	174.5
1.6	0.07	-114.8	34.96	64.0	0.0050	12.0	0.43	167.0
1.7	0.06	-147.1	32.25	50.6	0.0053	1.1	0.46	158.2
1.8	0.05	165.6	29.13	37.6	0.0056	-6.9	0.48	149.6
1.9	0.06	117.5	25.43	21.4	0.0061	-23.8	0.50	142.5
2	0.10	89.8	23.10	6.7	0.0063	-31.9	0.53	135.2
2.1	0.15	69.9	21.36	-7.7	0.0067	-33.5	0.56	127.7
2.2	0.21	53.8	19.35	-22.0	0.0085	-55.2	0.56	119.9
2.3	0.27	38.1	18.34	-36.7	0.0082	-59.6	0.58	113.0
2.4	0.35	22.9	16.61	-50.1	0.0094	-73.8	0.60	106.4
2.5	0.44	7.4	13.97	-66.8	0.0092	-82.0	0.62	100.3
2.6	0.51	-8.4	12.16	-87.6	0.0091	-96.0	0.65	94.9
2.7	0.59	-23.8	11.67	-107.0	0.0087	-113.3	0.68	87.9
2.8	0.66	-38.5	10.55	-118.9	0.0091	-129.3	0.72	81.1
2.9	0.73	-53.4	8.65	-131.4	0.0092	-141.3	0.75	73.7
3	0.77	-68.4	6.97	-148.5	0.0076	-155.1	0.80	66.0
3.5	0.83	-131.4	2.38	142.5	0.0036	146.3	0.91	24.2
4	0.73	175.3	0.47	99.7	0.0011	116.4	0.96	-15.4
4.5	0.50	132.7	0.42	-159.8	0.0016	-112.8	0.96	-54.4
5	0.31	107.1	0.88	155.7	0.0055	-177.3	0.94	-92.6
5.5	0.30	125.8	1.10	94.4	0.0100	140.6	0.90	-129.3
6	0.43	105.1	1.03	37.5	0.0150	71.5	0.86	-163.5
